

GEN2 FLEX+ ELEVATOR

The most adaptable elevator

OTIS



Same space, greater capacity



This elevator is ideal for any project, both new construction and refurbished buildings

- +** **UP TO 50% MORE CAPACITY**
From 4 to 6 passengers without construction work.
- +** **MINIMUM HOISTWAY DIMENSIONS**
Possible to install or to replace an elevator in tight spaces. It can also be installed in hoistways with low pits or overhead clearances.

Special configuration for elevators with two entrances at 90° and possibly panoramic elevators.
- +** **SAVINGS**
Maximize energy efficiency by combining LED lighting, standby-mode and regenerative technology as standard.
- +** **AESTHETICS**
Choose a design that compliments your project style with more than 400 000 custom combinations.

More passengers in the same space

FROM 4 PASSENGERS
CONVENTIONAL ELEVATOR

TO 6 PASSENGERS
GEN2 FLEX+ ELEVATOR

MACHINE ROOM

- 1 Controller
- 2 Machine
- 3 Overspeed governor

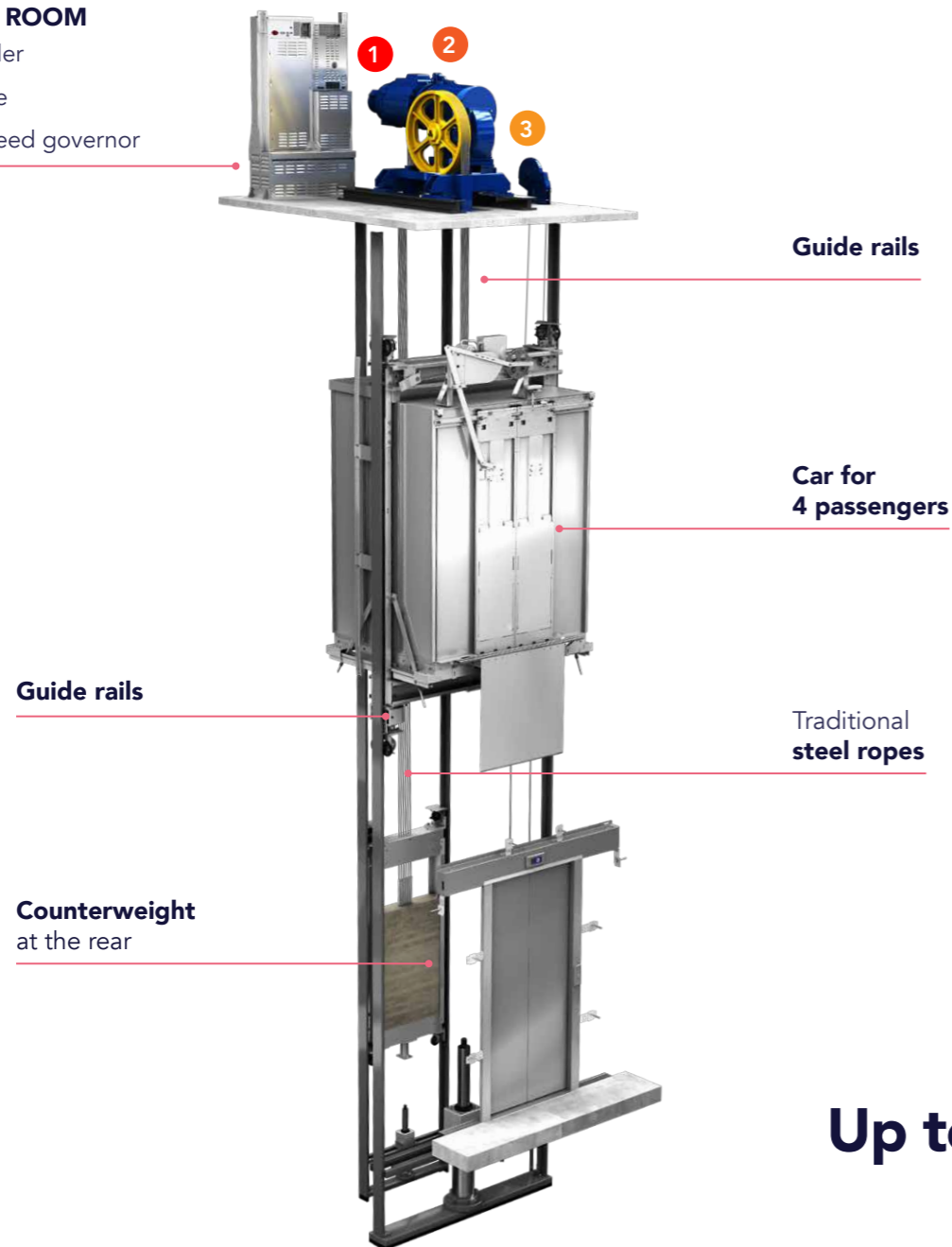

Machine room eliminated

Machine installed in the hoistway

Overspeed governor

Guide rails at the side

Counterweight at the side

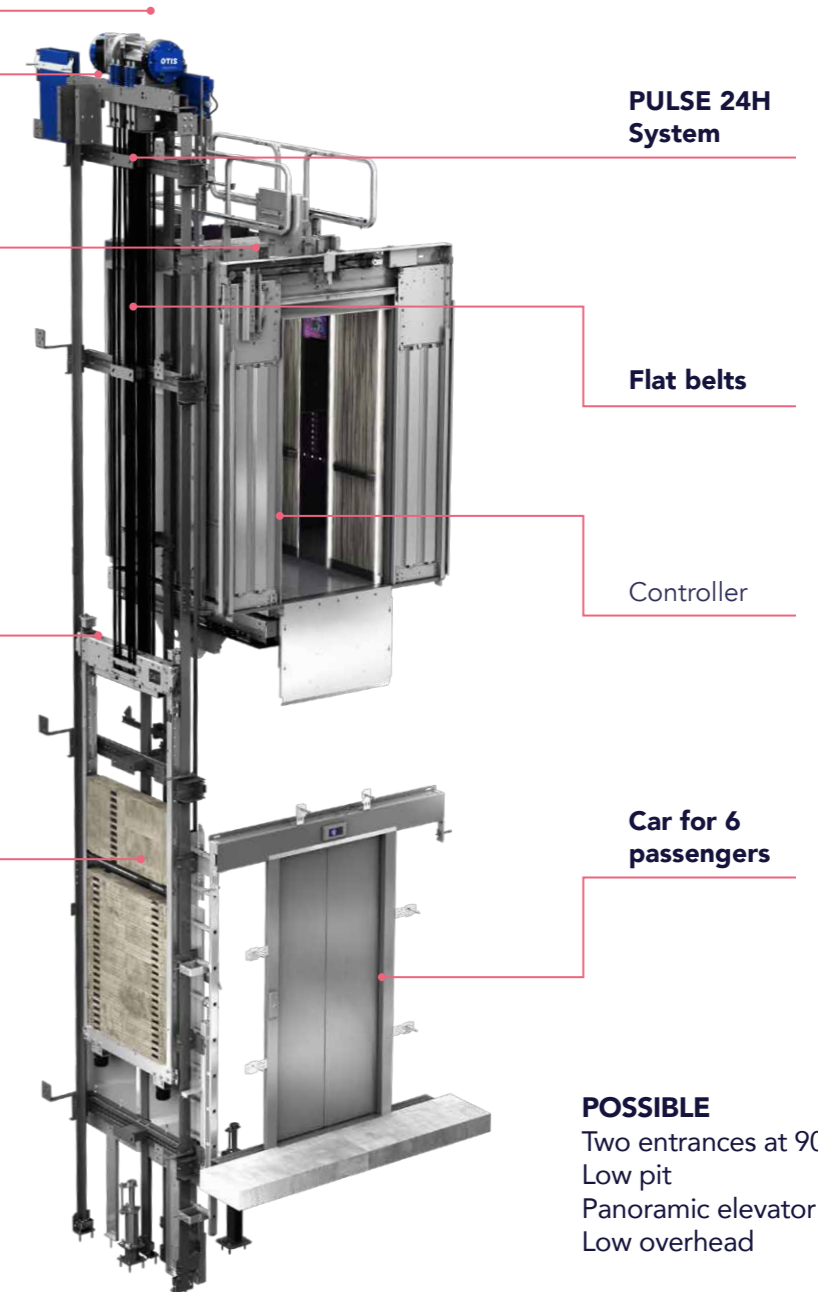

Up to 50% more capacity

POSSIBLE
Two entrances at 90°
Low pit
Panoramic elevator
Low overhead

Enjoy the technological advantages



COMFORT

The machine is 80% smaller than a conventional one, and thus allows it to be installed in the hoistway. You can use the machine room for another use as a cleaning room, lumber room etc.

The traditional ropes are replaced by flexible flat steel belts which provide a very smooth car operation and its variable frequency system guarantees starts and stops that are hardly noticeable.



RELIABILITY AND SAFETY

Thanks to the Pulse System, the flat belts are continuously monitored 24 hours a day, 7 days a week and last 3 times longer than traditional ropes.

The Gen2 Flex+ achieves outstanding stopping accuracy, making it easy to enter and exit the car and avoiding trips or falls.



ENERGY SAVINGS

The machine is up to 50% more efficient than a conventional geared machine.

The Gen2 Flex+ is equipped with a regenerative system, the ReGen Drive. In conventional elevator systems, the energy generated by the elevator is dissipated in the form of the heat. The ReGen Drive is able to capture this energy and feed it back into the building grid, where it can be used to power other electrical components.

Led lighting, up to 80% savings when combined with standby features.



SUSTAINABILITY

The flat belts and the machine are lubrication-free, thus contributing to environmental protection.



ENHANCED BUILDING

Installing a Gen2 Flex+ elevator increases a building's value, makes the property more accessible and residents' lives easier.



SILENT
COMFORTABLE
LOW CONSUMPTION

The cab colors are illustrative and may vary slightly from physical materials.

Gen2 Flex+ specifications

The Otis Gen2 Flex+ was engineered to fit into any type of hoistway and can be configured with the guide rails and the counterweight to one side or with the guide rails to both sides and the counterweight behind the car.

TRACTION EQUIPMENT

- Gearless sealed machine and permanent-magnet motor
- Traction by means of flat belts
- 2:1 configuration with cantilever type suspension

CONTROL

- Closed loop, variable frequency

CONTROLLER

- Modular microprocessor control system, combined with an advanced variable frequency, variable voltage drive
- Located in the landing door column on the top floor. As an option, it can be installed at a distance of up to 20 metres
- Two-way communication and remote intervention system

OPERATION

- Simple automatic. Down collective. Selective collective

TYPES OF DOORS

- Automatic telescopic doors, or centre-opening, or combination of BUS doors in car and semi-automatic on landing

ENTRANCES

- One or two entrances (90° and 180°)

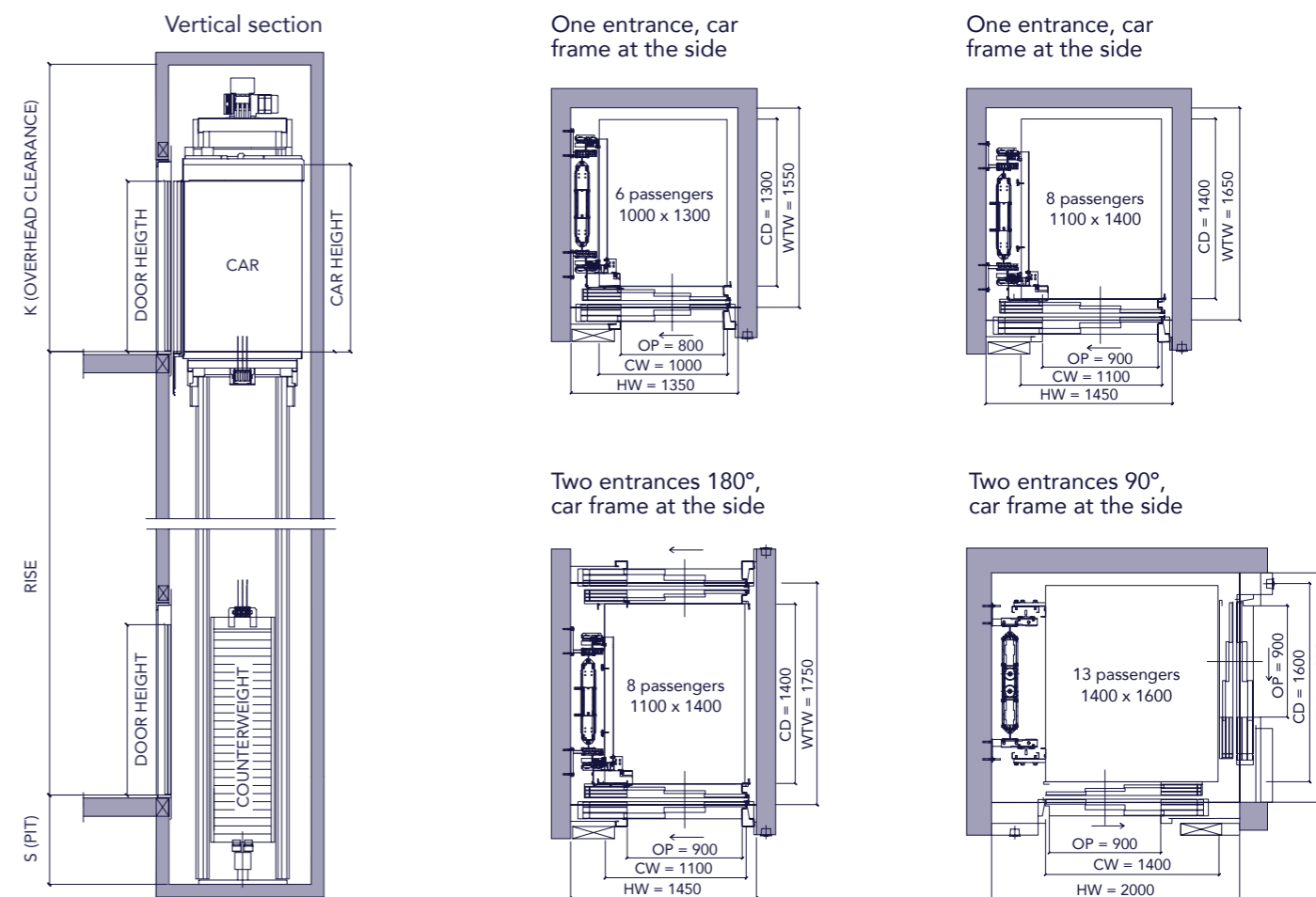

According to the Standard EN 81-70:2018, the car required for two entrances 90° installations is Type 4 with dimensions of 1400 x 1600 mm and a door 900 mm wide, and for one entrance and two entrances 180°, it is Type 2 with dimensions of 1100 x 1400 mm and a door 900 mm wide.

Consult Otis about other car and door dimensions, as well as other counterweight configurations at the rear and three entrances.

FOR CARS OF 3 TO 8 PASSENGERS (mm)

Door height	Car height	Standard overhead*	Minimum overhead**	Standard pit	Minimum pit Granite flooring	Minimum pit Rubber flooring	Dimensions of the controller cabinet 2100 mm high x 330 mm wide x 95 mm deep
2000	2100	3300	2600	1000	400	380	
2000	2200	3400	2600	1000	400	380	
2100	2300	3500	2700	1000	400	380	

Consult limitations in case of minimum safe overhead and/or pit.

* The safe overhead may be increased by 200 mm depending on the hoistway dimensions.

** In case of doors with 3 panels, it is increased by 200 mm.

FOR CARS OF 11 TO 13 PASSENGERS:

The minimum pit is always 1050 mm (consult rest of measurements). The controller will be the same size as for cars of 3 to 8 passengers, unless the rise is higher than 45 m which will have the controller of 2100 mm x 400 mm x 203 mm.

Duty Load (Kg)	225 to 630		900	1000
Passengers capacity	3 to 8 passengers		11 passengers	13 passengers
Car dimensions (mm) Counterweight on side-wall	Width	Variable 750 to 1250	1400	1400 1500
	Depth	Variable 790 to *1700	1400	1600 1500
Car dimensions (mm) Counterweight on rear-wall	Width	Variable 790 to 1500	-	-
	Depth	Variable 750 to 1250	-	-
Car entrances	One or two entrances 90° and 180°		Two entrances 90°	
Speed (in m/s)	1			
Maximum number of stops	16			
Maximum rise (m)	45			
Cars in groups	Up to 3			
Standard Power	380 - 400 - 415			
Frequency (Hz)	50 - 60			
Stopping accuracy (mm)	±3			

*Except two entrances, 1500 mm.

Natural and Modern Collections

New car designs that combine distinct forms, materials, textures and lighting. Two different collections: Natural and Modern, each of which has three finishes Standard, Advanced and Premium.

The car interior uses indirect LED lighting integrated into the four corners, creating a sensation of space and depth, and stressing the textures of the materials used.

eView

The constant work carried out by OTIS in research and design to create products that bring safety and comfort to elevators has made eView a reality.

eView is an innovative audiovisual intercom specifically designed for elevators, a unique product on the market.

This device provides two-way communication with Otis' 24-hour Service Centre by videoconference, offering passengers a greater feeling of comfort and security.

In addition, it acts as a broadcaster of general contents, news, weather forecasts, cultural information, etc.



The cab colors are illustrative and may vary slightly from physical materials.

— Otis gives people freedom to connect and thrive in a taller, faster, smarter world. The global leader in the manufacture, installation and servicing of elevators and escalators, we move 2.3 billion people a day and maintain more than 2.3 million customer units worldwide – the industry's largest Service portfolio. You'll find us in the world's most iconic structures, as well as residential and commercial buildings, transportation hubs and everywhere people are on the move. Headquartered in Connecticut, USA, Otis is 71,000 people strong, including 42,000 field professionals, all committed to meeting the diverse needs of our customers and passengers in more than 200 countries and territories. To learn more, visit www.otis.com and follow us on LinkedIn, Instagram and Facebook.

OTIS

otis.com

OTIS respects the environment. Recyclable material. When no longer required, please deposit in wastepaper container. OTIS, with the aim of improving the quality of its products, reserves the right to make any technical or aesthetical modifications, at any time without prior notice, to any of its models and components described in this publication, and therefore, OTIS does not guarantee either the availability or the specifications, colours, shapes or any other technical and aesthetical characteristics reproduced herein, coincide at all times with the real characteristics. The settings, drawings and artwork are for illustrative purposes only. For more information, please consult the sales representative of OTIS.