

ARISE ELEVATOR

Rise above expectations

OTIS



Versatile and cost effective

We believe everyone traveling the world, commuting to work or living their daily life is entitled to a safe, comfortable and reliable ride. To Otis, those features are our core values. With the Arise system, we focus on delivering an efficient and high-quality solution for your customers, tenants or passengers that changes how they experience your building.

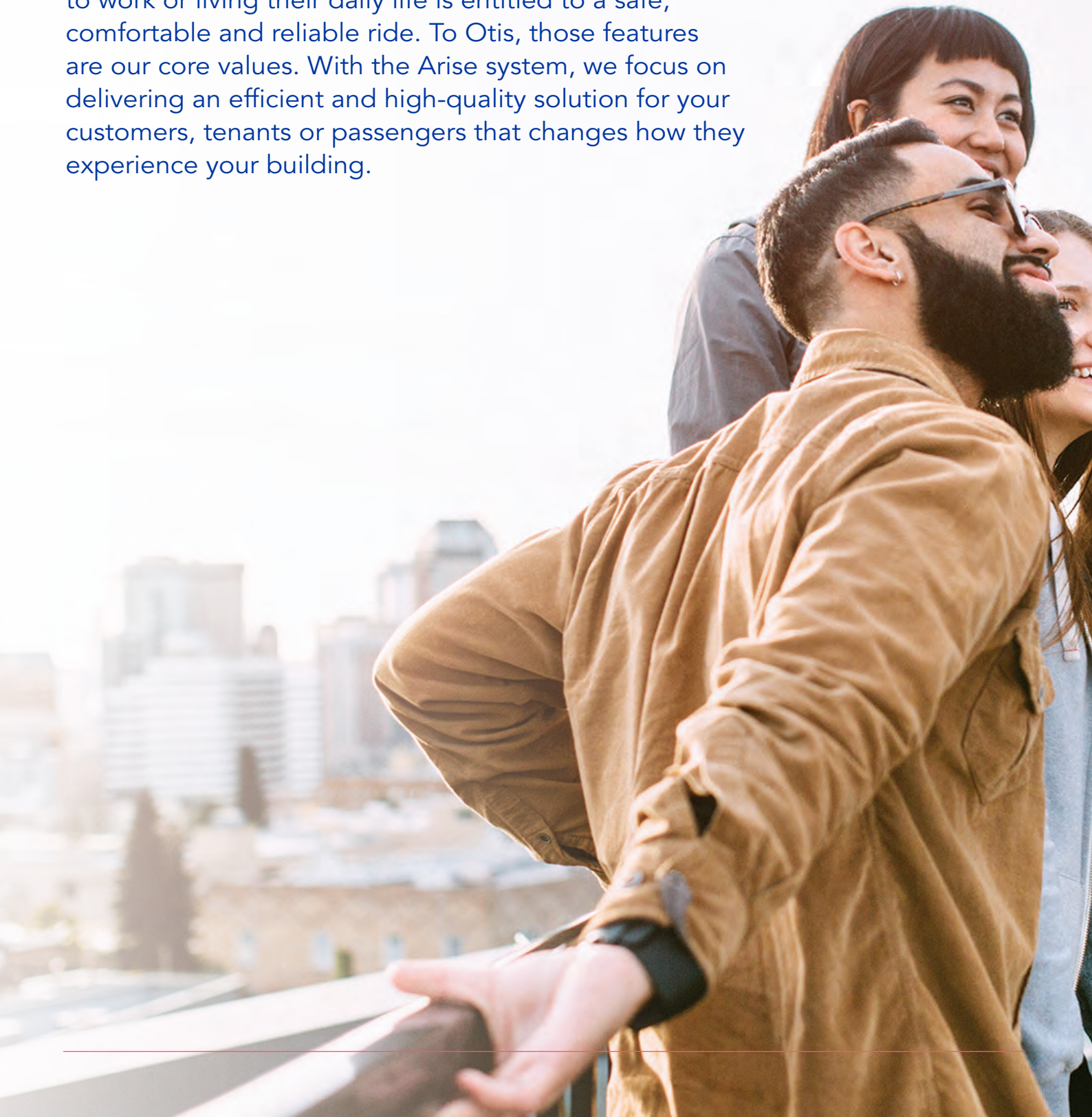

OTIS ARISE OVERVIEW

Maximum rise	130 m
Speed	1 – 2.5 m/s
Duty load	450 kg – 1600 kg
Maximum stops	36
Cars in group	Up to 8



A reliable way to move your world

At Otis, we go above and beyond code standards to ensure the Arise elevator stands the test of time, delivering more value for your building.

01. PureMotion high efficiency machine
02. Mini machine room
03. LED lighting & standby mode
04. Stringent door qualification
05. Otis qualified safety gears
06. Otis qualified buffers



WORLD-CLASS TESTING & QUALIFICATION

Recognized as worldclass by code authorities, supplier feedback and internal product benchmarking, our product qualification processes include:

- Exposure to harsh environmental conditions
- Advanced system dynamic tests
- Life cycle tests with a focus on safeties, governors and buffers



TOUGH LANDING DOORS

Our landing doors go through two stringent impact tests to cover everything from day-to-day passenger interactions to more intense cart or luggage impacts, exceeding EN 81-20 elevator code requirements.



PUREMOTION MACHINES

Our high-efficiency permanent magnet PureMotion machines meet Otis' strict engineering and quality control standards, getting passengers to their destinations smoothly and reliably.

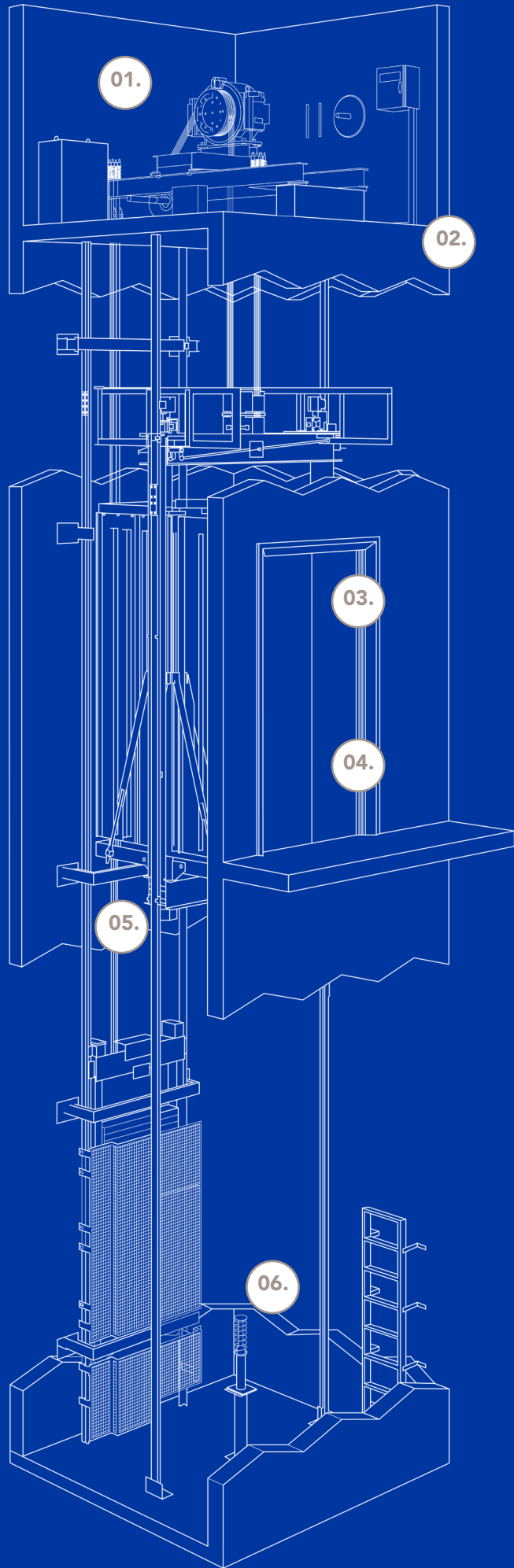

Safety and peace of mind

Since the invention of the Otis safety brake, safety has been a core promise of everything we do. So it wasn't enough for us to rely on basic safety code standards. We created our own set of even more demanding guidelines surpass global standards – the Otis Worldwide E3 policy. The parts and components of the Arise elevator undergo a battery of performance, safety and lifetime qualification testing that includes more than 50 critical safety tests during the manufacturing process.

+ GOVERNOR TRIPPING TEST
25%

MORE

*Exceed application code

+ BUFFER STRIKE TESTS
16x

MORE

*Exceed application code

+ SAFETY GEAR TESTS
6x

*Compared with GB7588-2003 A1 / EN81.1-1998





A commitment to exceptional service

We know what it takes to keep people safely and seamlessly on the move. Our founders were dedicated to delivering extraordinary service, and today we're continuing that promise with personalized and imaginative ways to meet our customers' every need.

Benefit from the industry's leading service offering, featuring 24/7 dedicated customer support through OTISLINE®, more intuitive access to information with the eService customer portal and our personal commitment to always put your needs first.



**Signature
Service™**



WE EARN YOUR TRUST — EVERY DAY

Our mechanics see your building as their own. With a global team of 31,000, we work around the clock to keep your equipment operating like new. The result is truly personalized service that ensures we build your trust over the lifetime of your equipment.

+

+

TURNING DATA INTO ACTION

As one of the first elevator companies to use big data and predictive analytics to improve performance, we're experts at getting the most out of emerging technology. Our digital ecosystem uses the "internet of things" and mobility tools to predict and diagnose issues before they occur. All of this to stay ahead of your needs and to deliver a seamless passenger experience.

A tailored solution for every lifestyle

From office buildings to condominiums and everything in between, having an elevator that completes your look is essential for your project and brand. With options such as hairline stainless steel and soft LED lighting, the Arise elevator will make your building stand out from the rest.



100 100

100 100



MODERN DESIGN

Clean tasteful design in every detail enhances your space.



STYLISH CEILINGS

Variety of ceilings with energy-efficient LED lighting.



DURABLE FIXTURES

LED full-scale displays with stainless steel faceplates.



FIXTURES

Our selection of ceilings, handrails and other fixtures is designed to harmonize with and enhance any building project.

CEILINGS



Standard:
B4100L



B4602L



4081L

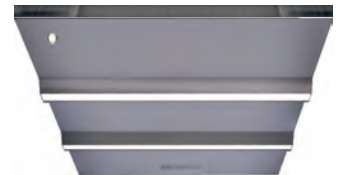

B4091L

CEILINGS

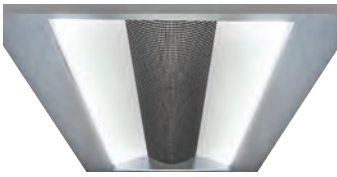

4180L



B4087L



B4095L

CAR OPERATING PANEL



COP16



HCOP

BUTTON TYPES



Standard:
BR34G



BR34GB



HBP16
Simplex



HBP16
Duplex

HALL FIXTURES

HANDRAILS

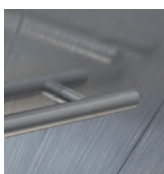

4900 - A



4900 - B



4900R - B



4900R - C

FLOORING



Standard:
4901 MA-0201

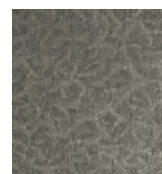

CARP01

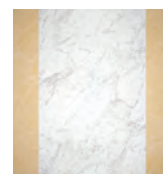

4901AH



4901DA

Arise specifications

REAR COUNTERWEIGHT

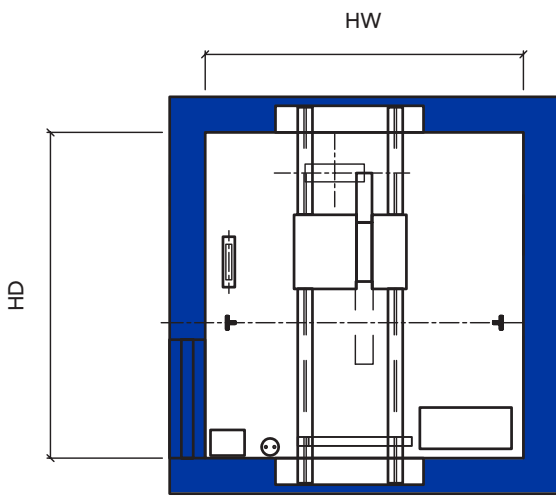

Typical Machine Room Plan

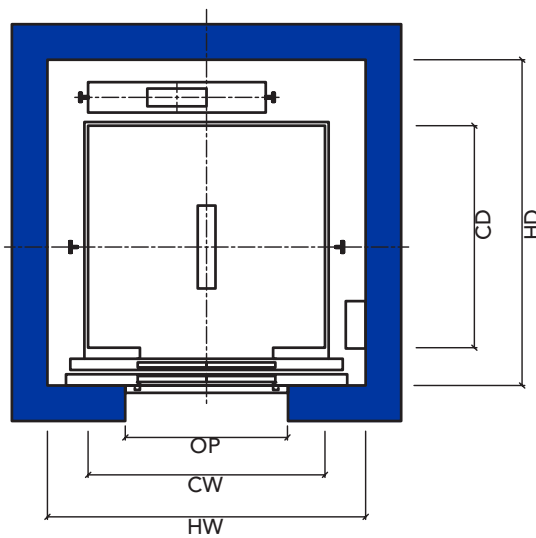

Hoistway Plan

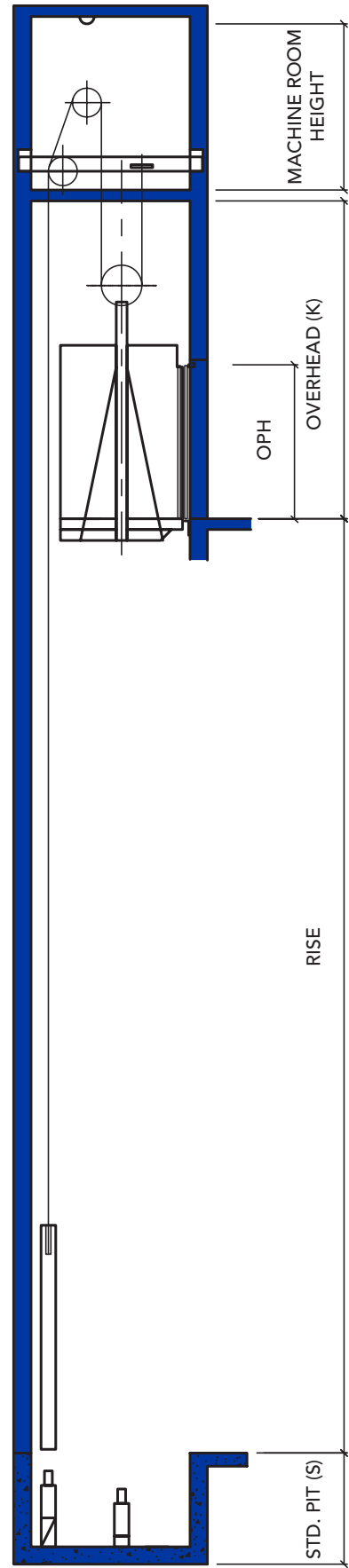

Elevation

Duty load (kg)	Speed (m/s)	STD. Pit (S) (mm)	STD. Overhead (K) (mm)	STD. Overhead (K) (mm)	Max. Floors	Max Rise (m)	Car in Group	Car Height (mm)	Runby
			EN81-1	EN81-20					
450-1000	1	1350	4150	4350	16	55	Up to 8	2400	200
	1.5	1400	4300	4500	36	80			
	1.75	1450	4350	4550		100			
	2	1600	4500	4700	40	110			
	2.5	1850	4750	4950		130			
1150-1600	1	1350	4250	4450	16	55			
	1.5	1500	4350	4550	36	80			
	1.75	1550	4450	4650		100			
	2	1600	4600	4800	40	110			
	2.5	1850	4800	5000		130			

Duty load (kg)	Speed (m/s)	Car (mm)		Door Opening (mm)	Hoistway (mm)		Machine Room Height (mm)
		Width (CW)	Ception (CD)		Width (HW)	Depth (CD)	
450	1-1.75	1100	700	900	1900	1750	2300
550	1-1.75	1200	1100	800	1900	1750	2300
							2500
630	1-1.75	1300					2300
							2500
680	1-1.75	1350	1150		1900	1800	2300
							2500
750	1-1.75	1400	1300		1950	1950	2300
	2-2.5						2500
800	1-1.75	1400	1350	800	1900	2000	2300
	2-2.5				1950		2500
900	1-1.75	1500	1400	900	2000	2100	2300
	2-2.5						2500
1000 (1050)	1-1.75	1600	1400	900	2150	2200	2300
	2-2.5						2500
1150	1-2.5	1850	1350	1100	2600	2000	2500
1350	1-2.5	1900	1550	1100	2600	2200	2500
1600	1-2.5	2000	1700	1100	2600	2350	2500

Arise specifications

SIDE COUNTERWEIGHT

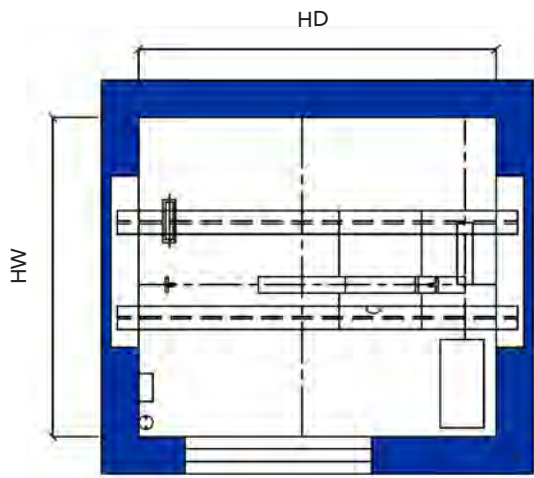

Typical Machine Room Plan

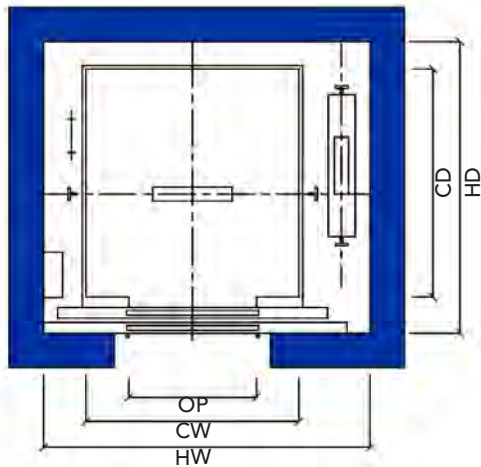

Hoistway Plan

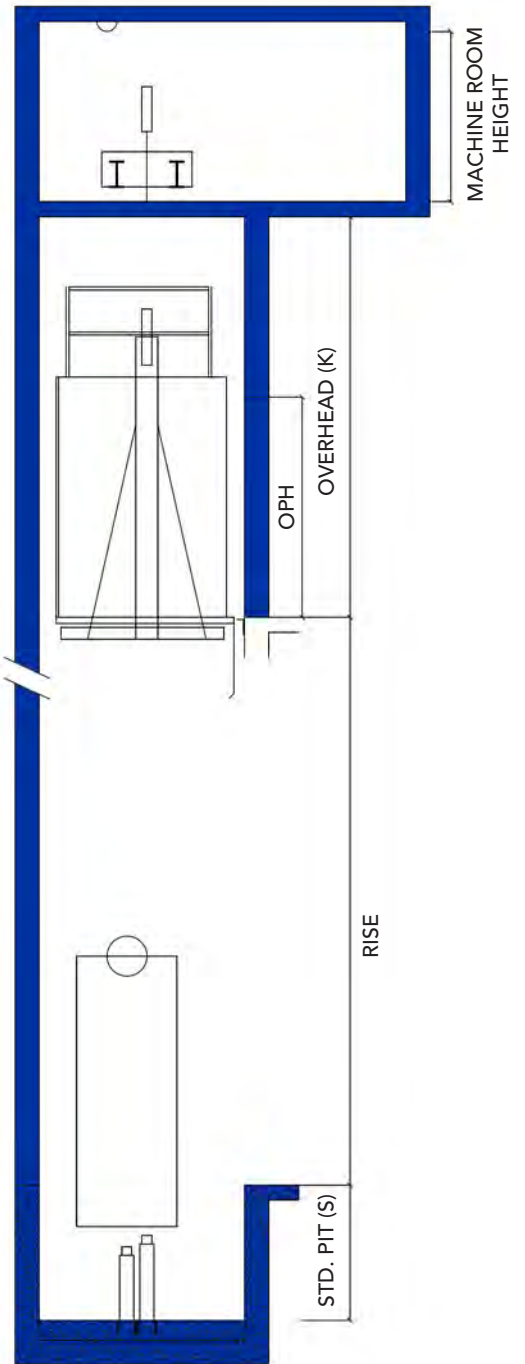

Elevation

Duty load (kg)	Speed (m/s)	STD. Pit (S) (mm)	STD. Overhead (K) (mm)	STD. Overhead (K) (mm)	Max. Floors	Max Rise (m)	Car in Group	Car Height (mm)	Runby		
			EN81-1	EN81-20							
450-1000	1	1350	4150	4350	16	55	Up to 8	2400	200		
	1.5	1400	4300	4500	36	80					
	1.75	1450	4350	4550		100					
	2	1600	4500	4700	40	110			250		
	2.5	1850	4750	4950		130					
1150-1600	1	1350	4250	4450	16	55			Up to 8	2400	200
	1.5	1500	4350	4550	36	80					
	1.75	1550	4450	4650		100					
	2	1600	4600	4800	40	110					250
	2.5	1850	4800	5000		130					

Duty load (kg)	Speed (m/s)	Car (mm)		Door Opening (mm)	Hoistway (mm)		Machine Room Height (mm)	
		Width (CW)	Cepth (CD)		Width (HW)	Depth (CD)		
450	1-1.75	1100	1100	700	2050	1750	2500	
550	1-1.75	1200	1100	800			2100	2500
								2700
630	1-1.75	1300	1100	800	2200	1800	2500	
680	1-1.75	1350	1150	800			2200	2700
								2500
750	1-1.75	1350	1350	800	2200	1900	2500	
	2-2.5						2700	
800	1-1.75	1400	1350	800	2200	1900	2500	
	2-2.5						2700	
900	1-1.75	1400	1500	900	2200	1950	2500	
	2-2.5						2700	
1000 (1050)	1-1.75	1400	1400	900	2300	2050	2500	
	2-2.5						2700	
1150	1-2.5	1600	1650	1000	2500	2250	2700	
1350	1-2.5	1600	1850	1000	2500	2400	2700	
1600	1-2.5	1400	2400	900	2250	2800	2700	

Let's build something unique, together

For more than 160 years, Otis has set the gold standard in the industry. But leading the industry means more than being first – we improve what we do each and every day.

From helping commuters with a reliable daily route to guiding travelers to new adventures, we help more than 2 billion people get to their next destination each day. And we care for every single one.

We take the experience we've gained from building and installing approximately 2.6 million Otis elevators and escalators in nearly 200 countries and use it to continually build our strengths to move our products toward higher standards.

ARISE ELEVATORS COMPLEMENT OTHER VERSATILE OTIS PRODUCTS



GEN2 ELEVATORS

High-performance elevator series for residential and commercial buildings.



LINK & CROSSLINK

Escalators and moving walkways for retail buildings, airports and metros.



SKYRISE ELEVATORS

Elevators for high-rise buildings.

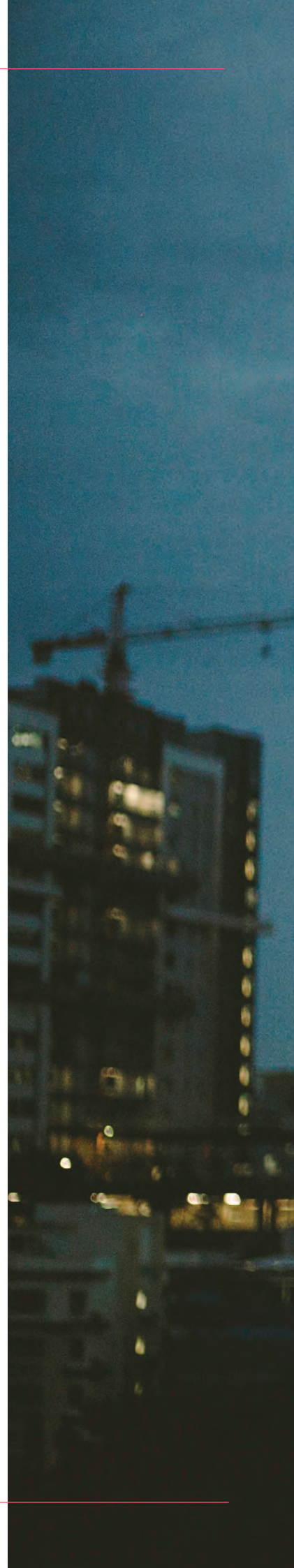



Built on a legacy of innovation, Otis was founded in 1853 after Elisha Otis invented the elevator safety brake, giving rise to the modern city, transforming how people live and work, and revolutionizing architecture itself. Today, we are the world's leading company for elevator and escalator manufacturing, installation and service. We move 2 billion people a day and maintain more than 2 million customer units worldwide, the industry's largest maintenance portfolio. We can be found in many of the world's most recognizable buildings, as well as the busiest transportation hubs and retail centers – we are everywhere people are on the move. Headquartered in Connecticut, USA, Otis is 69,000 people strong, including 40,000 field professionals, all committed to meeting the diverse needs of our customers and passengers in more than 200 countries and territories worldwide. To learn more, visit www.otis.com and follow us on LinkedIn, Instagram, Facebook and Twitter @OtisElevatorCo.